

MFS

Metal Fabrication Services

ORDER FORMS MANUAL



1 (800) 285-3056
metalfabricationsvcs.com

Serving the Needs of Our Customers Since 1923



EBERL IRON WORKS, INC.

Founded in 1923, by brothers George and Frank Eberl, EIW began as a small welding shop, fabricating wrought iron railings, exterior fire escapes and miscellaneous iron.

We've come a long way since those days. We now specialize in custom shearing and forming of steel sheets and plates. Working with customer specifications, we are dedicated to providing the highest quality formed shapes out of: hot rolled, cold rolled, galvanized and stainless steel, as well as aluminum and copper.

We have a selection of custom products for Original Equipment Manufacturers, and for the Structural and Miscellaneous Steel Industries, including: bent plate, canopy hoods, industrial pipe guards, gutter guards, corner guards, pour stop, concrete forms, masonry clips, curtain wall clips, metal hems, and more.

HOW TO USE THIS MANUAL

This manual was designed to help customers obtain quotes for bent plate and other custom fabricated items. Simply locate and download or print the form for the desired item, fill the form out and then return it to us for a quote.

Be sure to fill in all dimensions, including: quantity, material thickness, and length. Note any special requirements such as notching, punching, or painting.

Forms are fillable and may be completed on your device and emailed, or printed and filled out by hand, then faxed or scanned and emailed back to us.

Quotes are typically turned around in 1 business day or less.

SAMPLE

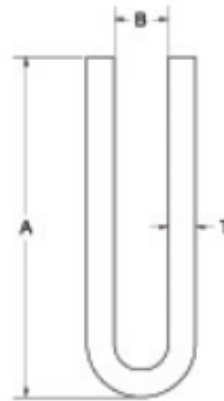

Custom formed steel Sheet Metal Hems are used to enclose expanded metal, wire meshing and perforated sheet steel. Hems provide a smooth u-shaped edging around exposed ends of jagged sheet steel. Common applications include; handrail filler panels, wire screening and architectural designs. Eberl Iron Works, Inc. Hems are rigid and weldable providing cost effective protection to fabricated filler panels. Eberl Iron Works, Inc utilizes CNC equipment and quality tooling to assure accurate dimensions and quality on our custom fabricated steel hems.

MATERIAL:

Hot Rolled, Cold Rolled, Galvanized
Stainless Steel, and Aluminum
20 ga - 1/2" depending on material type

OPTIONAL FINISHES:

Primer Coat Painted, Hot Dip Galvanized,
and Powder Coated

QTY	T	MATERIAL	A	B	LENGTH	FINISH
50	14ga	HR Steel	1"	3/8"	10'	none

BENT PLATE

METAL ANGLE

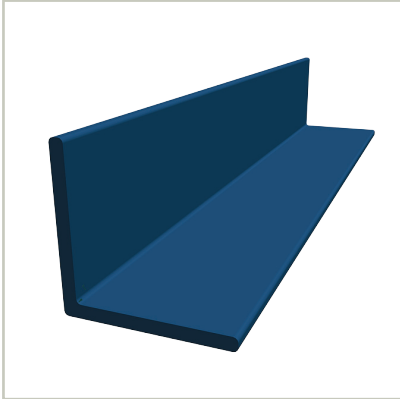

METAL CHANNEL

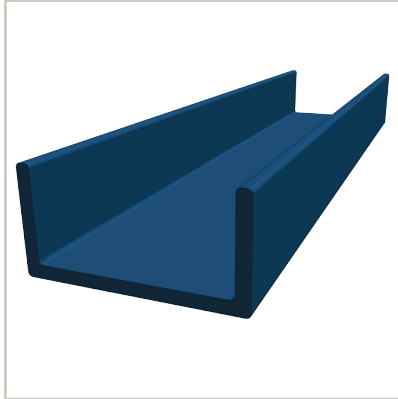

C-CHANNEL

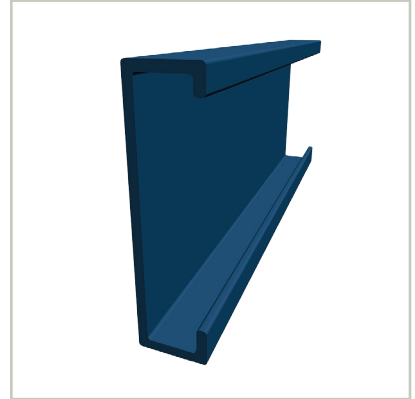

Z-CHANNEL

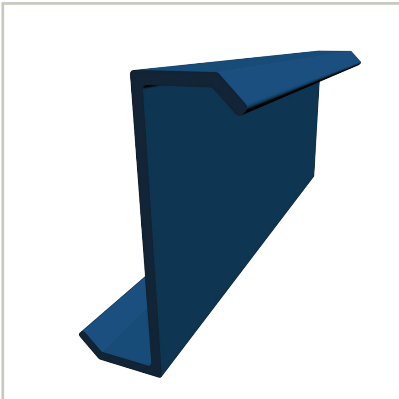

TAPERED CHANNEL

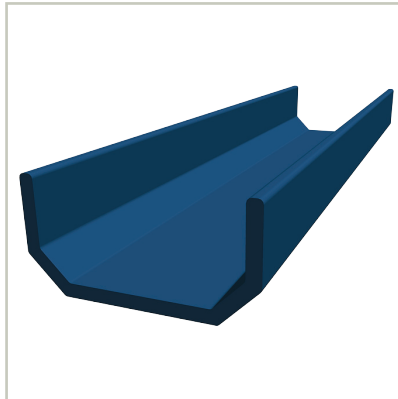

HAT CHANNEL

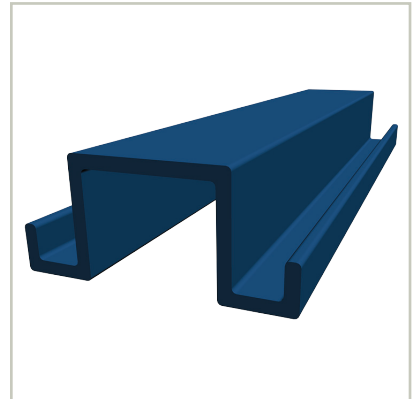

HAT SECTION

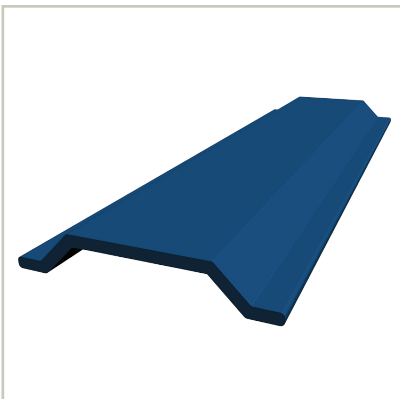

ANGLED CLIPS

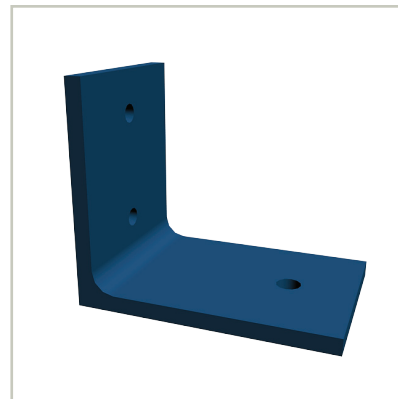

DOWNSPOUT COVERS

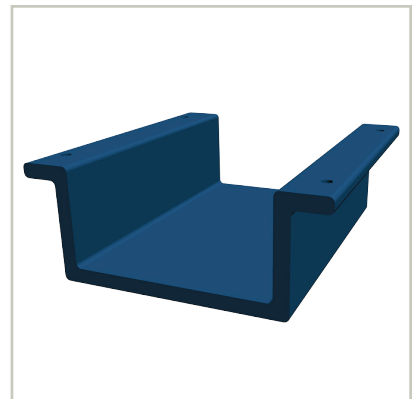

CAPABILITIES

We now offer Plasma Cutting up to 1-3/4" mild steel plate, as well as Metal Shearing on plates between 20 gauge and 1/2" thicknesses, up to 12 feet in length. We shear flat bar in the following sizes: 1/2" thick by 20" wide, 3/4" thick by 18" wide, and 1" thick by 12" wide.

We also offer Metal Forming services. Our four Press Brakes can handle material as thin as 20 gauge and up to 3/8" thick, by 12 feet in length. We can form 1/2" thick material by 6 feet in length.

Other services we offer include: Laser Cutting, Welding, Turret Punching, Powder Coating, and Painting.

We use CNC equipment, along with a highly skilled workforce, to ensure the tightest tolerance levels, the most accuracy, and the highest efficiency on all of our metal fabrication jobs, to save you time and money.



MATERIALS

Our 40,000 square foot facility is stocked with a large array of materials, so we can fabricate your custom job at a moment's notice.

Because we offer so many different fabrication services in house, we are able to tightly control the manufacturing process.

This allows us to provide you with a superior standard of quality and quick turnaround time on your orders.

BENT PLATE:

ANGLE

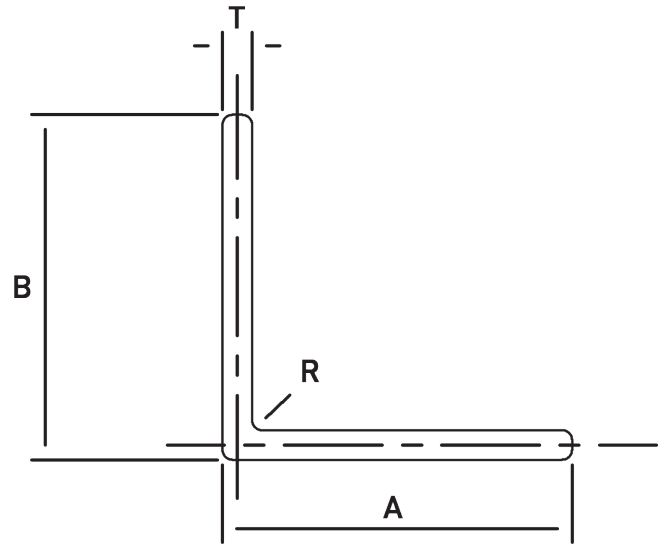
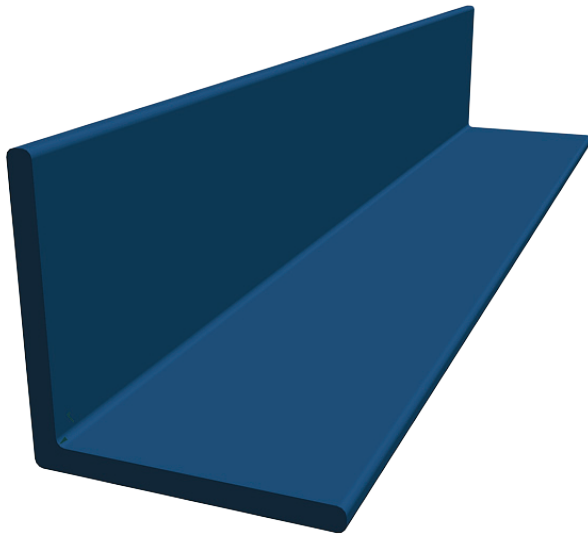

Bent Plate Angles are used for a variety of customer designed applications. Whether they're being used for concrete pour stop, lintels, corner guards, equipment framing or building enclosures; custom formed angles offer a strong cost effective option. Eberl Iron Works, Inc. utilizes CNC equipment and quality tooling to assure accurate dimensions and quality on our custom steel forms.

MATERIAL:

Hot Rolled, Cold Rolled, Galvanized
Stainless Steel, and Aluminum
20 ga - 1/2" depending on material type

OPTIONAL FINISHES:

Primer Coat Painted, Hot Dip Galvanized,
and Powder Coated

Holes/Patterns: Available upon request

QTY	T	MATERIAL	A	B	R	LENGTH	FINISH

A Division of Eberl Iron Works, Inc.
128 Sycamore Street
Buffalo, NY 14204
metalfabricationsvcs.com

MFS
Metal Fabrication Services
1 (800) 285-3056
email: fab@eberliron.com

BENT PLATE:

CHANNEL

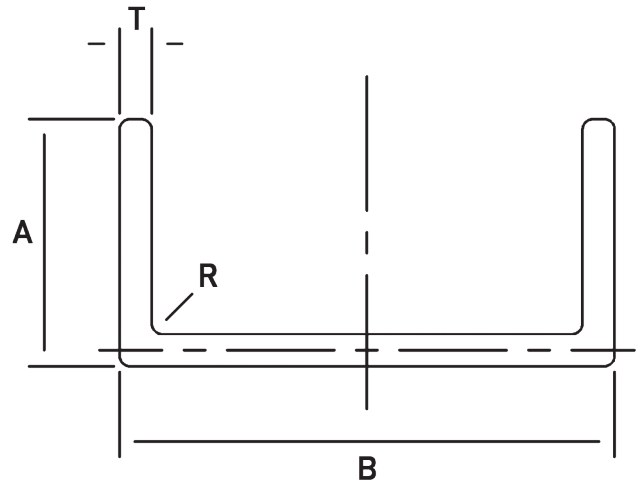
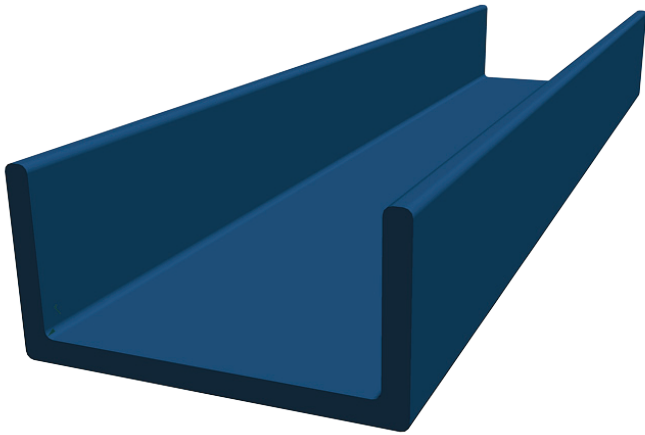

Bent Plate Channel is used for a variety of customer designed applications. Whether they're being used for Ibeam enclosure, landing pans, door jambs, stair treads, equipment framing or building enclosures; custom formed channels offer a strong cost effective option. Eberl Iron Works, Inc. utilizes CNC equipment and quality tooling to assure accurate dimensions and quality on our custom steel forms.

MATERIAL:

Hot Rolled, Cold Rolled, Galvanized
Stainless Steel, and Aluminum
20 ga - 1/2" depending on material type

OPTIONAL FINISHES:

Primer Coat Painted, Hot Dip Galvanized,
and Powder Coated
Holes/Patterns: Available upon request

QTY	T	MATERIAL	A	B	R	LENGTH	FINISH

A Division of Eberl Iron Works, Inc.
128 Sycamore Street
Buffalo, NY 14204
metalfabricationsvcs.com

MFS
Metal Fabrication Services
1 (800) 285-3056
email: fab@eberliron.com

BENT PLATE:

C-CHANNEL

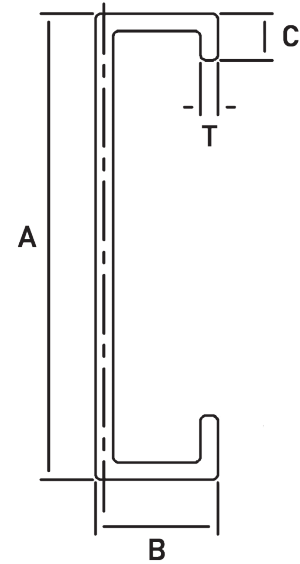
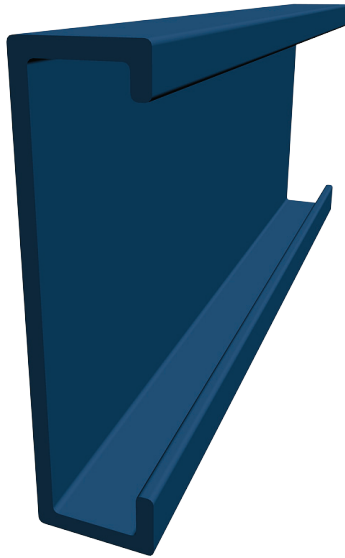

Bent Plate C-Channels are used for a variety of customer designed applications. Whether they're being used for girts, perlines, sub-girts, stair treads or building framing; custom formed channels offer a strong cost effective option. Eberl Iron Works, Inc utilizes CNC equipment and quality tooling to assure accurate dimensions and quality on our custom steel forms.

MATERIAL:

Hot Rolled, Cold Rolled, Galvanized
Stainless Steel, and Aluminum
20 ga - 1/2" depending on material type

OPTIONAL FINISHES:

Primer Coat Painted, Hot Dip Galvanized,
and Powder Coated

Holes/Patterns: Available upon request

QTY	T	MATERIAL	A	B	C	LENGTH	FINISH

BENT PLATE:

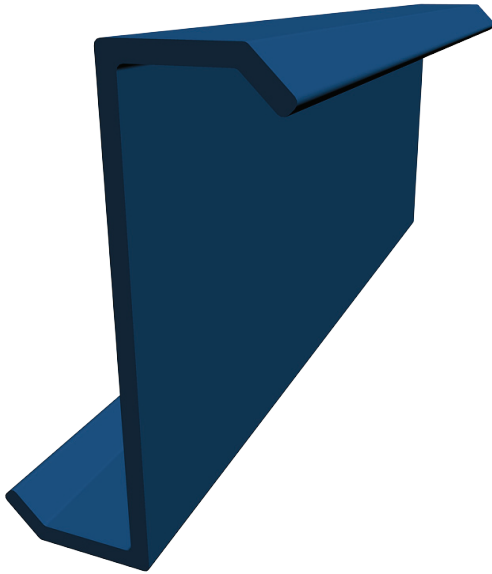

Z-CHANNEL

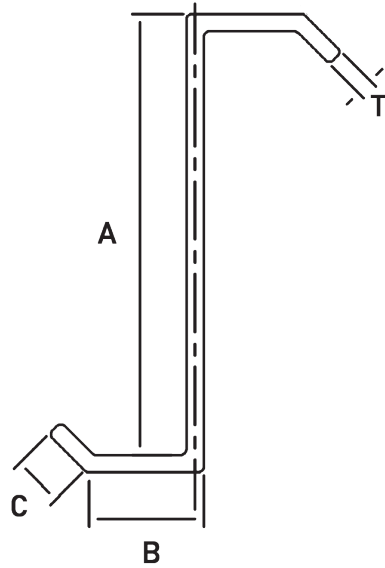

Bent Plate Z-Channels also known as formed Z-Bars, are used for a variety of customer designed applications. Whether they're being used for girts, sub-girts, perlin, stair treads or building framing; custom formed Zees offer a strong and cost effective option. Eberl Iron Works, Inc. utilizes CNC equipment and quality tooling to assure accurate dimensions and quality on our custom steel forms.

MATERIAL:

Hot Rolled, Cold Rolled, Galvanized
Stainless Steel, and Aluminum
20 ga - 1/2" depending on material type

OPTIONAL FINISHES:

Primer Coat Painted, Hot Dip Galvanized,
and Powder Coated
Holes/Patterns: Available upon request

QTY	T	MATERIAL	A	B	C	LENGTH	FINISH

A Division of Eberl Iron Works, Inc.
128 Sycamore Street
Buffalo, NY 14204
metalfabricationsvcs.com

MFS
Metal Fabrication Services
1 (800) 285-3056
email: fab@eberliron.com

BENT PLATE:

TAPERED CHANNEL

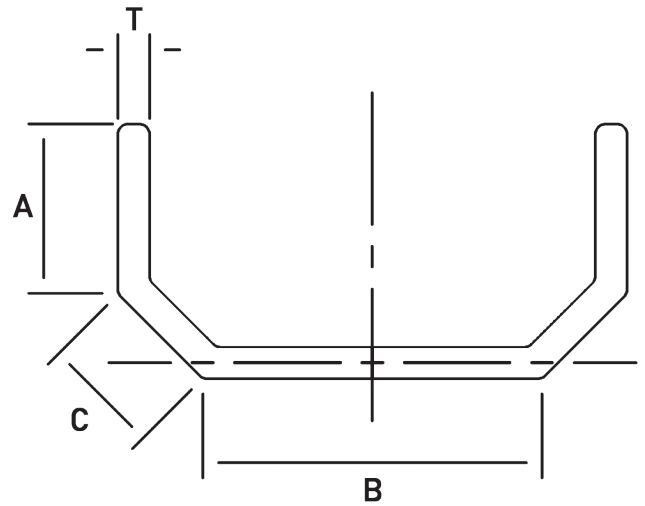
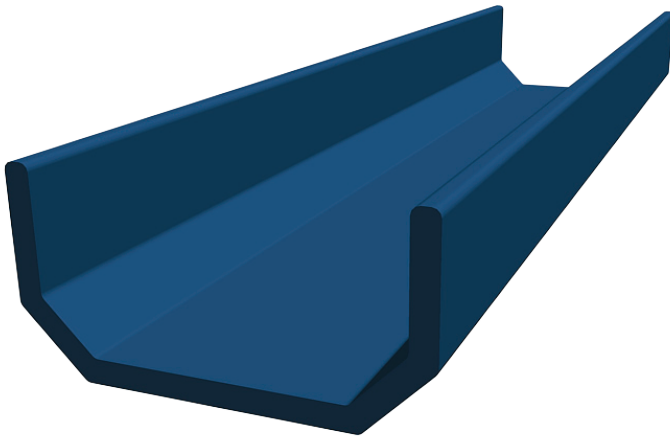

Bent Plate Tapered Channel is used for a variety of customer designed applications. Whether they're being used for door jambs, pipe guards, equipment guards or building framing; custom formed tapered channels offer a strong cost effective option. Eberl Iron Works, Inc. utilizes CNC equipment and quality tooling to assure accurate dimensions and quality on our custom steel forms.

MATERIAL:

Hot Rolled, Cold Rolled, Galvanized
Stainless Steel, and Aluminum
20 ga - 1/2" depending on material type

OPTIONAL FINISHES:

Primer Coat Painted, Hot Dip Galvanized,
and Powder Coated
Holes/Patterns: Available upon request

QTY	T	MATERIAL	A	B	C	LENGTH	FINISH

BENT PLATE:

HAT CHANNEL

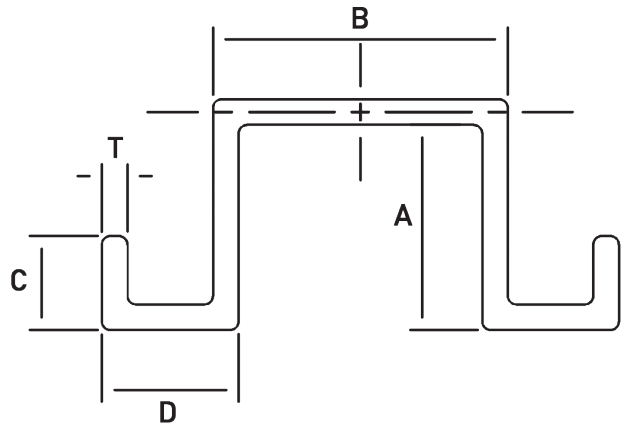
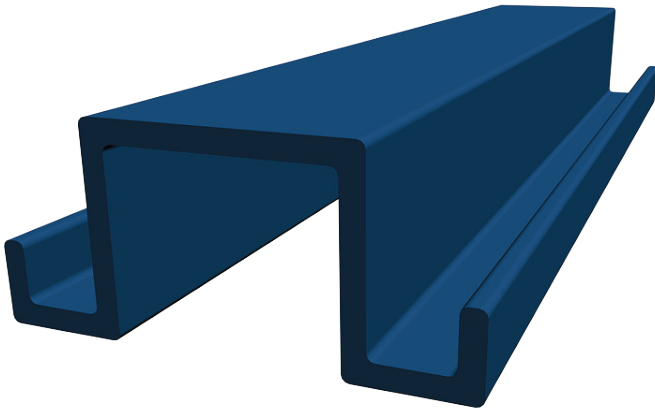

Bent Plate Hat Channels are used for a variety of customer designed applications. Whether they're being used for girts, sub-girts or perlines custom formed hat sections with return offer a strong and cost effective option. Eberl Iron Works, Inc. utilizes CNC equipment and quality tooling to assure accurate dimensions and quality on our custom steel forms.

MATERIAL:

Hot Rolled, Cold Rolled, Galvanized
Stainless Steel, and Aluminum
20 ga - 1/2" depending on material type

OPTIONAL FINISHES:

Primer Coat Painted, Hot Dip Galvanized,
and Powder Coated

Holes/Patterns: Available upon request

QTY	T	MATERIAL	A	B	C	D	LENGTH	FINISH

A Division of Eberl Iron Works, Inc.
128 Sycamore Street
Buffalo, NY 14204
metalfabricationsvcs.com

MFS
Metal Fabrication Services
1 (800) 285-3056
email: fab@eberliron.com

BENT PLATE:

HAT SECTION

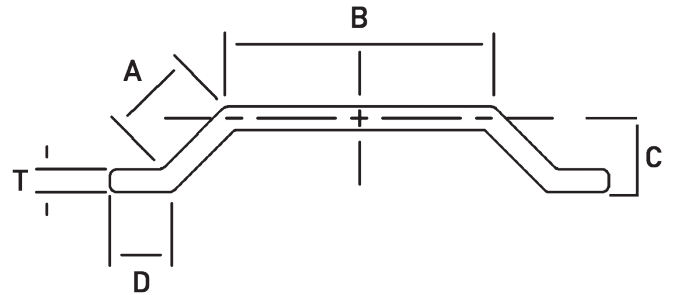
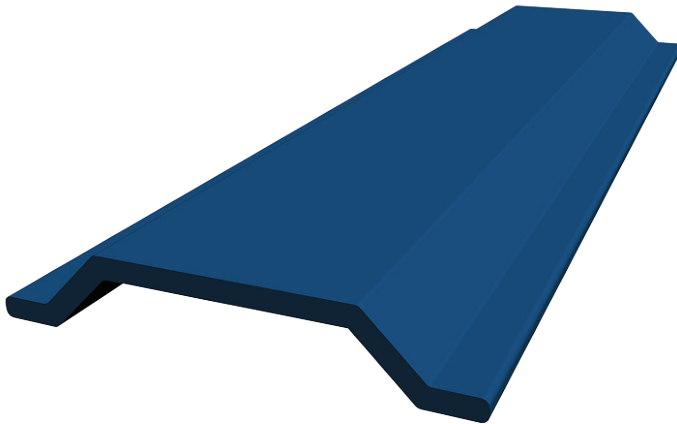

Bent Steel Plate Hat Sections are used for a variety of customer designed applications. Whether they're being used for sub-girts, perlines, expansion joint covers, cable crossovers and building framing; custom formed hat sections offer a strong and cost effective option. Eberl Iron Works, Inc. utilizes CNC equipment and quality tooling to assure accurate dimensions and quality on our custom steel forms.

MATERIAL:

Hot Rolled, Cold Rolled, Galvanized
Stainless Steel, and Aluminum
20 ga - 1/2" depending on material type

OPTIONAL FINISHES:

Primer Coat Painted, Hot Dip Galvanized,
and Powder Coated
Holes/Patterns: Available upon request

QTY	T	MATERIAL	A	B	C	D	LENGTH	FINISH

BENT PLATE:

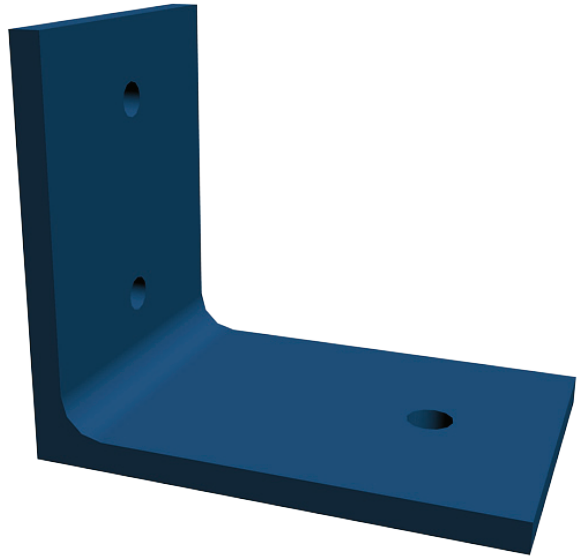

ANGLE CLIPS

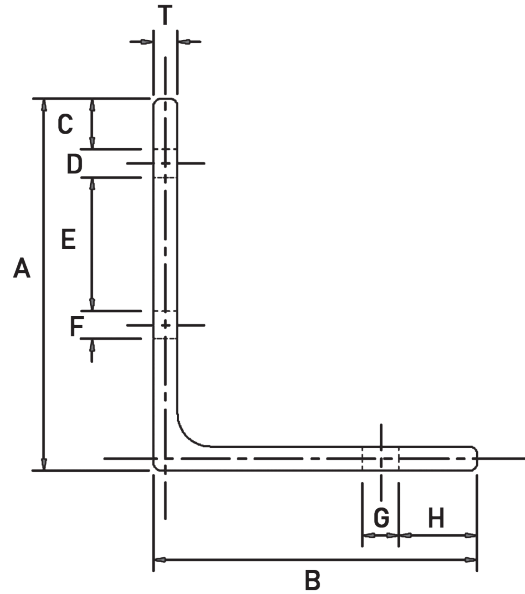

Bent Steel Plate Angle Clips are used for many connection applications. Uses include curtain wall, concrete masonry and for structural steel connections. Eberl Iron Works, Inc. utilizes CNC equipment and quality tooling to assure accurate dimensions and quality on our custom steel forms.

MATERIAL:

Hot Rolled, Cold Rolled, Galvanized
Stainless Steel, and Aluminum
20 ga - 1/2" depending on material type

OPTIONAL FINISHES:

Primer Coat Painted, Hot Dip Galvanized,
and Powder Coated

Holes/Patterns: Available upon request

QTY	T	MTRL	A	B	C	D	E	F	G	H	LGT	FIN

A Division of Eberl Iron Works, Inc.
128 Sycamore Street
Buffalo, NY 14204
metalfabricationsvcs.com

MFS
Metal Fabrication Services
1 (800) 285-3056
email: fab@eberliron.com

BENT PLATE:

DOWNSPOUT COVERS

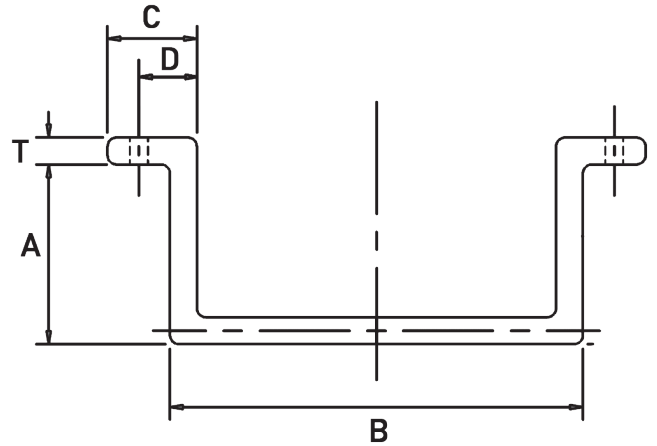
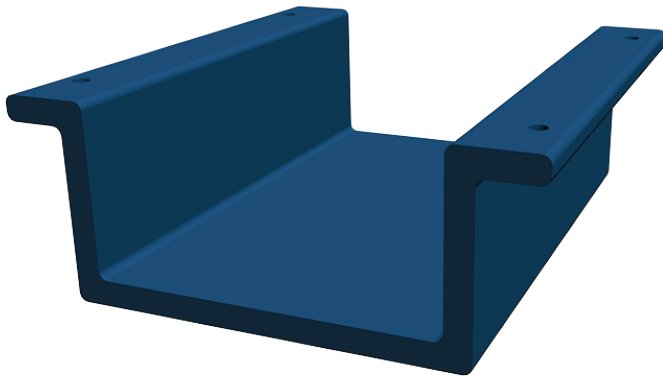

Bent Plate Down Spout Covers are used for a variety of customer designed applications. Whether they're being used protecting pipes, electrical cabling, ductwork and other building mechanicals that would be damaged by facility vehicles. Custom formed down spout guards offer a strong cost effective option. Eberl Iron Works, Inc. utilizes CNC equipment and quality tooling to assure accurate dimensions and quality on our custom steel forms.

MATERIAL:

Hot Rolled, Cold Rolled, Galvanized
Stainless Steel, and Aluminum
20 ga - 1/2" depending on material type

OPTIONAL FINISHES:

Primer Coat Painted, Hot Dip Galvanized,
and Powder Coated
Holes/Patterns: Available upon request

QTY	T	MATERIAL	A	B	C	D	LENGTH	FINISH

SHEET METAL HEMS

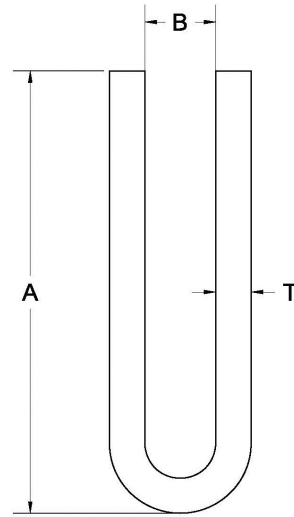

Custom formed steel Sheet Metal Hems are used to enclose expanded metal, wire meshing and perforated sheet steel. Hems provide a smooth u-shaped edging around jagged, exposed ends of sheet steel. Common applications include; handrail filler panels, wire screening and architectural designs. Eberl Iron Works, Inc. Hems are rigid and weldable providing cost effective protection to fabricated filler panels. Eberl Iron Works, Inc utilizes CNC equipment and quality tooling to assure accurate dimensions and quality on our custom fabricated steel hems.

MATERIAL:

Hot Rolled, Cold Rolled, Galvanized
Stainless Steel, and Aluminum

OPTIONAL FINISHES:

Primer Coat Painted, Hot Dip Galvanized,
and Powder Coated

Thickness: 14 gauge - 10 gauge

QTY	T	MATERIAL	A	B	LENGTH	FINISH

A Division of Eberl Iron Works, Inc.
128 Sycamore Street
Buffalo, NY 14204
metalfabricationsvcs.com

MFS
Metal Fabrication Services
1 (800) 285-3056
email: fab@eberliron.com

Eberl Iron Works, Inc.
128 Sycamore Street
Buffalo, NY 14204
1 (800) 285-3056
Local: (716) 854-7633
Fax: (716) 854-1184
Email: fab@eberliron.com



Metal Fabrication Services

metalfabricationsvcs.com



Shipping & Delivery

We keep a large selection of products in inventory so we can cut our lead times down and fulfill orders in as few days as possible. Our extremely high shipping volumes are a major contributing factor to our ability to provide highly competitive product pricing and delivery throughout North America. All of our quotes include delivery to your chosen destination.

Your parts are skidded, bound, and marked for delivery. Bundles are neatly nested when possible, strapped, or boxed and shrink wrapped. Each order is marked per your job prints for EASY location and assembly because we recognize that your time is valuable. We take pride in delivering accurate, clean, pre-sorted components, on time.